

MULTIDOS[®] H Weighfeeder

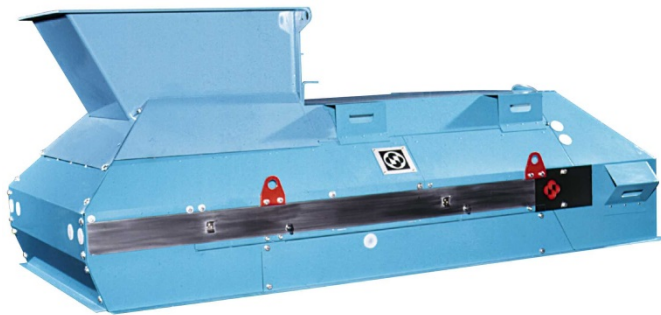

- For bulk solids of most diverse properties
- Wide performance range
- Mechatronic design with integrated electronics
- Safe belt run monitoring and tracking
- Easy belt change without auxiliaries

Application

Schenck Process weighfeeders are used for continuous and gravimetric feeding of bulk solids.

Their rugged design makes them suitable for the harsh demands of industrial operation in the rock, sand and gravel, metal and basic material, chemical and animals feed industries.

Application oriented types and the high quality standard of the Schenck Process weighfeeders ensure economical solutions even to highly sophisticated feeding tasks.

The first-class measuring, control and supervisory electronics enables comprehensive monitoring of weighfeeders.

The Mechatronic variant permits easy integration into plant control at a very reasonable price.

This results in:

- Minimal investment and sequential costs (operating and maintenance costs)
- Little installation effort and low space requirements
- Improved accuracy and quality of the final product

Construction

The weighfeeder standard equipment comprises:

- Rugged feeder mechanics
- Automatic belt tracking
- Plough scraper (diverting foreign objects on return belt to the side)
- Belt outside scraper
- Static belt tension through take-up screws integrated in frame
- Belt influence compensation (BIC).

Accessories are optional:

- Dust-tight enclosure of varying extent:
 - Discharge hood
 - Belt cover
 - Side and rear cladding
 - Complete cladding
- Integral chain conveyor for cleaning of mounting surface.

Operating Principle

Designed for continuous feeding as well as for the batching of bulk solids, the MULTIDOS® H weighfeeder consists of:

- Belt conveyor
- Drive with speed sensor for belt speed acquisition
- Material prefeeder, e.g. hopper with bed depth setter
- Integrated belt scale, and
- Measuring and control electronics.

The electronic measuring and control system is designed to determine feed rate m (kg/hr) by multiplication of belt load q (kg/m) and belt speed v (m/s), and to keep the preset feed rate value constant with the use of a closed-loop control.

For weighfeeder function and accuracy, the belt scale assembly is of central importance.

The Schenck Process weighfeeders use electronic single-idler belt scales. One idler is acquired by two hermetically sealed stainless strain-gauge load cells.

The weighing electronics measures the resulting force G of the material located on the above belt section between the two opposed carrying idler.

Belt load q results from the quotient from force G and the distance between the two idlers, i.e. weigh span L .

Feed rate is computed from value q multiplied by the belt speed.

Feed rate totalization over the time finally supplies the amount fed out.

The belt influence is considered with the aid of the belt influence compensation (BIC).

The infeed hopper is an essential prerequisite for the reliable operation of the weighfeeder. Various types can be selected in accordance with material properties:

- Feed hoppers mechanically designed for specific materials
- Vibration feed hoppers for bridging materials
- Settling chambers for fluidizable material.

Version 1
Standard

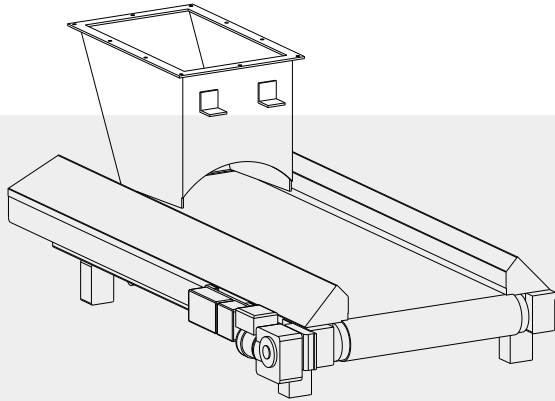

Version 2
Optional with discharge hood

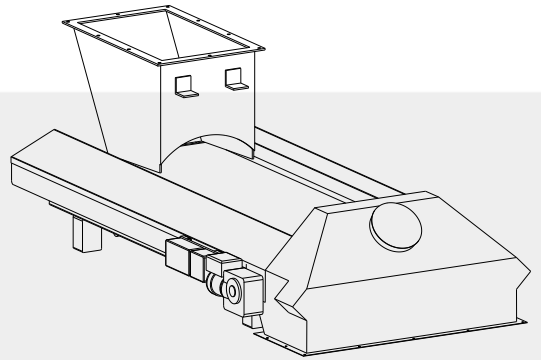

Version 3
Optional with discharge hood and belt cover

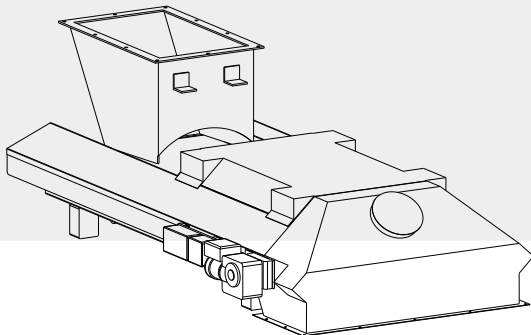

Version 4
Optional with discharge hood, belt cover and side and rear cladding

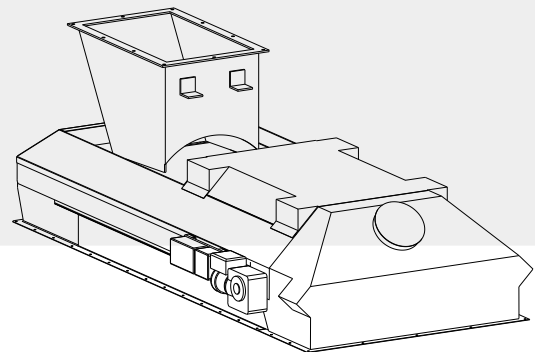

Technical Data

Accuracy (related to actual value): $\pm 0.25 \dots 0.5 \%$
 Conveying speed: max. 0.5 m/s
 Material temperature: 80 °C with standard, 130 °C and 170 °C with special variants

Belt width [mm]	Feed rate max.	
	Volumetric m ³ /h	Gravimetric t/h (with $\gamma = 1.5 \text{ t/m}^3$)
1400	690	1030
1600	800	1200
1800	915	1370
2000	1025	1530

Dimensions [mm]

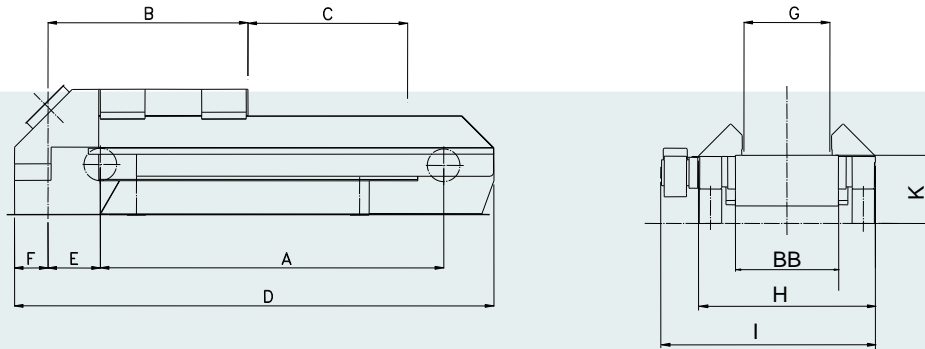

	Distance pulley to pulley* A						Belt width BB			
	2700	3500	4500	5500	6500	7500	1400	1600	1800	2000
B	1732	1732	1732	1732	1732	1732				
C	1000	1800	2800	3800	4800	5800				
D	3731	4531	5531	6531	7531	8531				
E	384	384	384	384	384	384				
F	269	269	269	269	269	269				
G							1325	1525	1725	1925
H							1915	2115	2315	2515
I							2365	2565	2765	2965
K							638	638	638	638

* Further pulley distances on request

Schenck Process Europe GmbH
Pallaswiesenstr. 100
64293 Darmstadt, Germany
T +49 6151 1531-0
F +49 6151 1531-66
sales@schenckprocess.com
www.schenckprocess.com